

The winning movement

Mighty & Powerful
Reliable & Precise



THE WINNING MOVEMENT
DITEC is the new partner of Ducati Corse.
Winners meet (automatically).



Expertise, the automatic choice

**Automatic gates, doors,
entrances:
better rely on the experience
of the DITEC experts
in the field!**

**Qualified professionals
all over the world.**



We are at your disposal for:

Project

- ✓ Analysis of the client's needs.
- ✓ Integration of the automatic entrance in the architectural infrastructure.
- ✓ Choice of the best solution.
- ✓ Tailor-made system.
- ✓ Surveys at the client's.
- ✓ Assistance to the building designer and to installer.

Installation

- ✓ Turnkey solutions.
- ✓ Integration in the client's infrastructure.
- ✓ Mounting of the structural, electrical, automation, safety and control parts.
- ✓ Safety and quality certifications for products and installations.

Service

- ✓ Quick appliance repair service.
- ✓ Qualified technicians.
- ✓ Spare parts.
- ✓ New regulations.
- ✓ Maintenance.



The certainty
of a total guarantee:
guaranteed expertise,
guaranteed products.



DITEC offers comfort, motion and safety. Thanks to its wide range of products and design solutions, you can automate any indoor and outdoor entrance in a house, company, building or shop. Find out the solution that best suits your needs in this catalogue.

Residential Sector

Automations for sliding gates	5
Automations for swing gates	6
Underground automations	7
Automatic systems for garage doors	7
Automatic sectional overhead garage doors	8
Automatic systems for doors and frames	9
Automatic systems for swing doors	11



Commerce and Service Sector

Automatic entrances	13
Automatic barriers	19
Flexible doors	19



Industrial Sector

Automations for gates	21
Automatic systems and automatic entrances	22
Automatic sectional overhead doors	23
Industrial flexible doors	24

Accessories

Accessories	28
-------------	----



Set your house in motion



Gates, garage doors, external frames, internal doors, awnings and curtains, private road barriers: 1,000 accessories for 1,000 solutions. DITEC, the automatic entrance specialists, have specific solutions for any requirement and plenty of solutions to improve the quality of your life. **Automatically, everything becomes easier!**

Automations for sliding gates

Highly compact automations. Easy to install. Total reliability and safety.
Essential and elegant design.



CROSS 3E

For gates up to 300 kg



24 V DC power supply

Total safety thanks to its low voltage. Continuous operation also in case of power failure, combined with battery backup device.



CROSS 5E - 7E - 7EH - 8E

For gates: 400 kg (Cross 5E)
600 kg (Cross 7E-7EH) - 800 kg (Cross 8E)



CROSS 14 - 14E - 14VE - 15V

For gates up to 1400-1500 kg



CROSS 30 - 30E

For gates up to 3000 kg

DITEC. Solutions for any requirement

- Gate size
 - for gates up to 5 m
 - for gates up to 3,000 kg
- Type of application
 - residential/condominiums
- Gate design and structure
- Also operates in case of a power break.

▶ Automations for swing gates

Don't waste energy.

Choose the right automation for the weight and size of your gate. Sturdy and untiring.



▶ Distinctive features of the available versions

	OBBI 3BH	SILVER 1B	SILVER 40B	LUXO 3B -3R	LUXO 5B	LUXO 5BH	ARC B	ARC BH
Electromechanical actuator	Non-reversible	Non-reversible	Non-reversible	Non-reversible / reversible (3R)	Non-reversible / reversible	Non-reversible / reversible	Non-reversible	Non-reversible
Maximum load capacity	250 kg x 1,5 m 150 kg x 3 m	300 kg x 2,5 m 200 kg x 3,5 m	400 kg x 2,5 m 150 kg x 5 m	350 kg x 2,5 m 250 kg x 3,5 m	500 kg x 3 m 250 kg x 5 m	500 kg x 3 m 250 kg x 5 m	500 kg x 3 m 250 kg x 5 m	200 kg x 2 m 150 kg x 2,5 m
Type of duty	frequent	frequent	frequent	heavy	heavy	heavy	frequent	heavy



Elegant, vertical design.



Elegant design - solid structure.



Sturdy and untiring. Ideal for heavy duty and condominium installation.



Special actuator with articulated arm. Necessary in case of gates mounted on very big or not perfectly vertical pillars.

Underground automations

Concealed but functional system. Keeps the beauty of your gate unspoiled.
Ideal for prestige gates.



Opening up to 180°. Sturdy and untiring.
Suitable for gates of up to 800 kg.



External lever arm. Ideal even in case of extremely
difficult applications. Suitable for gates of up to 2.5 m.



Automatic systems for garage doors

For practical, easy and quick opening and closing of garage doors.
Easy to install. No frame modification required. Total reliability. Maximum safety.



For spring balanced doors or sectional
overhead doors.



Ideal for counterweight balanced doors.

DITEC automatic sectional overhead doors

The modern solution for your garage door. They complement the environment, improve the quality of your life, comply with safety requirements.

DITEC sectional overhead doors replace traditional garage doors, offering a series of functional and amazing advantages.

- ▶ **Easy and trouble-free opening and operation.**
They are easy to operate. With DITEC motorization all you have to do is use the door remote control and the door will silently open, sliding upwards along the side tracks, positioning itself parallel to the ceiling.
- ▶ **Make your life easier.**
- ▶ **They take up very little space, thereby leaving more room at your disposal inside and outside your garage.**
Thanks to the side runners and positioning parallel to the ceiling, DITEC doors make better use of available internal space.
- ▶ **Heat insulation and soundproofing.**
Heat insulated and soundproof panels, combined with silent operation resulting from the advanced technology of DITEC automatic systems will improve the liveability of your house.
- ▶ **They enhance the environment and cater for all requirements.**
The design and different solutions adopted allow these doors to perfectly complement any architectural style, either classic, rustic or modern.

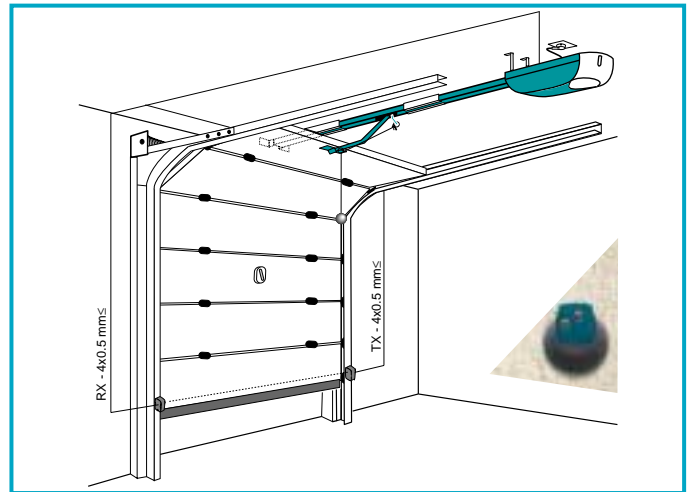

Automatic systems for doors and frames

Sturdy and reliable automations. Safe and smooth motion. Full range of accessories. Battery backup in case of power failure.

DITEC automatic doors: the right solution. Plenty of advantages, no drawbacks.



RADIUS

Ideal for shutters.



OLLY E

Ideal for windows, partitions, awnings, curtains. Can also be fitted on already existing frames, **without modification.**



DOK

For frames, sliding shutters, French windows, mobile walls, curtains and awnings. **Can also be fitted in the case of very long measurements.**





Ideal for internal sliding doors.
To help elder or disabled people move around the house.



What they offer	
- Comfort.	- Balance temperature.
- Prestige.	- Save energy in air-conditioned rooms.
- Safety.	- Help overcome architectural barriers.



Reduced-size automation for internal concealed doors.
Also suitable for already existing doors, **without modification.**



▶ Automations for swing doors



WEL



Motor opening and spring closing, can always be closed even in case of power break.



SPRINT



Push & Go and Low Energy functions. Suitable for places where there are disabled people.

▶ Automations for swing doors

▶ Distinctive features of the available versions

"ENCODER" system. Automatically slows down movement at end of stroke, thereby avoiding frame stress.

Courtesy light. Lights up the doorway and ensures easier transit.

ODS safety device. Controls and stops opening/closing if an obstacle is detected.

MPS device. Runs the motor at full power to overcome friction caused by ice or sand.

Battery backup device that also ensures operation in case of a power break.

Key lock release device for manual operation.

Pre-flashing signal to clear passageway and make transit safer.

Immediate radio control closing.

RF force regulator. To provide best thrust for correct operation.

Open gate signal. To indicate the gate is not completely closed.

Microprocessor technology control panel to ensure controlled and safe motion in every situation.

Synthetic drive belt for silent operation.

Nylon sliding wheels, indeformable and silent.

24 V DC power supply.

Wide range of accessories available.

	Gate / Garage	Doors / Frames
"ENCODER" system. Automatically slows down movement at end of stroke, thereby avoiding frame stress.	●	●
Courtesy light. Lights up the doorway and ensures easier transit.	●	
ODS safety device. Controls and stops opening/closing if an obstacle is detected.	●	●
MPS device. Runs the motor at full power to overcome friction caused by ice or sand.	●	
Battery backup device that also ensures operation in case of a power break.	●	●
Key lock release device for manual operation.	●	●
Pre-flashing signal to clear passageway and make transit safer.	●	
Immediate radio control closing.	●	
RF force regulator. To provide best thrust for correct operation.	●	●
Open gate signal. To indicate the gate is not completely closed.	●	
Microprocessor technology control panel to ensure controlled and safe motion in every situation.	●	●
Synthetic drive belt for silent operation.	●	●
Nylon sliding wheels, indeformable and silent.		●
24 V DC power supply.	●	●
Wide range of accessories available.	●	●

Set your business in motion



Shops, hotels, offices require both functional and prestige solutions. After all doors are like visiting cards, the first "contact" with a commercial or service sector environment. DITEC offers the widest range of automatic doors able to make access easier and enhance the prestige of the building in which they are integrated with cutting-edge technological solutions and finishes that integrate perfectly with the style of the building.

No limits to the imagination!
No limits to DITEC applications!

The widest range of automatic entrances

Sturdy and reliable automation. Safe and trouble-free motion.
Full range of accessories.
Battery backup in case of power failure.



EXEO

Revolving door. To enhance the prestige of the building.
Maintains a balance between inside/outside temperatures. Keeps out dust, exhaust fumes and noise.



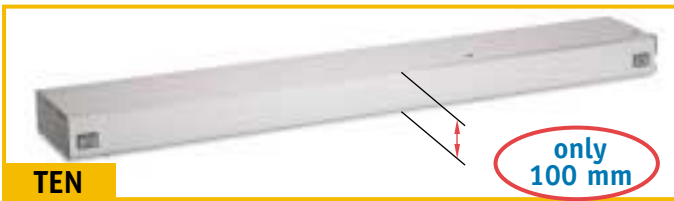

TEN



Automations for straight sliding doors.



TEN, REX, BIS

Automations for straight sliding doors.

Computer-controlled, fast motion.

Ready for the future and for computer science technology integration.

Time saving and cost effective.

Users such as supermarkets, hotels, hospitals, offices and airports can monitor and control all their entrances from a centralised control office PC.



GTS-P

Automation for straight sliding doors.

Ideal for regular heavy traffic, totally reliable and sturdy structure suitable for heavy doors.



Automation for telescopic sliding doors. Wide doorway opening. Ideal for regular heavy traffic.



Automation for curved sliding doors.



Automation for internal, concealed doors.
Can also be installed on already-existing frames, **without modification.**



OLLY E

Ideal for windows, partitions, curtains and awnings.



CIVIC

Automation for internal sliding doors. Soft and smooth motion.

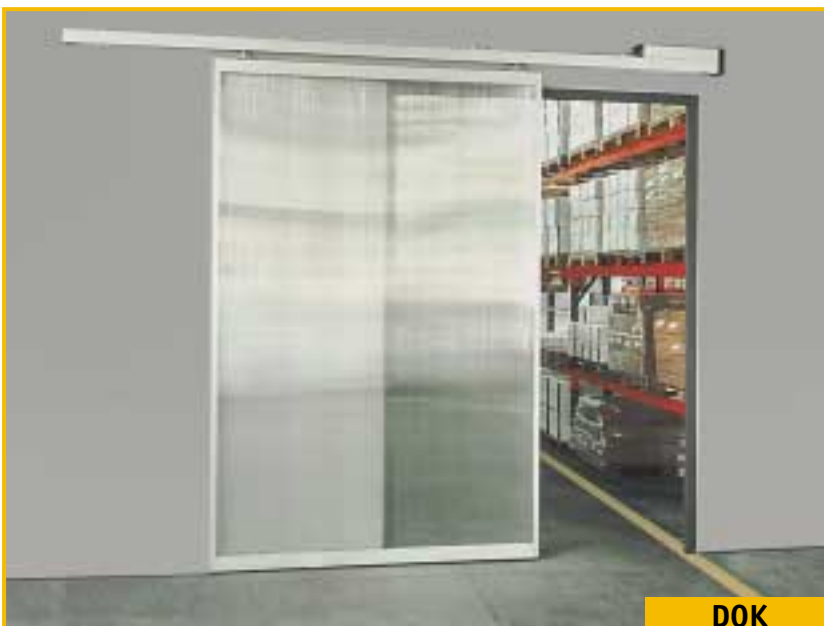

DOK

Universal motorized track. Ideal to move frames, mobile walls, shutters, French windows, curtains and awnings, industrial doors, drop-curtains. Versatile and sturdy automatism, no building works, frame adaptation or modification required.



New, multi-functional, solid, adaptable and noiseless.

Wel is the new automation for automatic swing doors. Its distinctive features make it an all-purpose product which can be used in different operational situations:

- with motor opening and closing;
- with motor opening and spring closing;
- on escape routes;
- on fire-proof doors;
- low energy for the disabled.

Wel is a sturdy, hard-wearing, heavy-duty and noiseless automation that can also be fitted to double synchronised doors (master-slave function).

Wel's novel and elegant design gives it a very smart appearance.

Wel complies with the most stringent European standards.

PUSH AND GO
A gentle push
for automatic opening

LOW ENERGY
Opening and closing at
reduced speed and energy



WEL



Compact and high-performance. Ideal for residential use.

Compact and low-weight automation ideal for residential use.

Already provided with a UPS battery fitted inside the automation and with an easy-access ON/OFF button.

User transit is easy and functional.

Low Energy and Push and Go modes can be selected.

The Low Energy function enables low-speed and low-energy opening/closing, making Sprint especially suitable for physically-handicapped people.

The Push and Go function is also a standard feature. This is indispensable for enabling automatic opening by means of an initial manual push.

Functional, safe and dependable

Sprint is safe to use thanks to a standard anti-crush device and reliable because it can, if necessary, be manually operated in case of a power break.

These and other distinctive characteristics make Sprint one of the world's leading automations for swing doors in the residential sector.

PUSH AND GO
A gentle push
for automatic opening

LOW ENERGY
Opening and closing at
reduced speed and energy



SPRINT



Your "tailor-made" entrance.



PAM

Profiles and seals designed to complete automatic sliding doors.
Doors can be made according to specific requirements.
Effective heat insulation and soundproofing.
ASMI/ASME anti-panic break-out function and AST anti-panic total break-out function.
Safety standards in compliance with applicable regulations.

▶ Automatic systems for entrances

▶ Distinctive features of the available versions

"ENCODER" system. Automatically slows down movement at end of stroke, thereby avoiding frame stress.

Safety device that controls and stops opening/closing if an obstacle is detected.

Battery backup device that also ensures operation in case of a power break.

Key lock release device for manual operation.

RF force regulator. To provide best thrust for correct operation.

Microprocessor technology control panel to ensure controlled and safe motion in every situation.

Synthetic drive belt for silent operation.

Nylon sliding wheels, indeformable and silent.

24 V DC power supply.

Wide range of accessories.

DITEC fully automates your business.

Discover the range of available solutions in the other sections of the catalogue.

Gates

Garages

Industrial flexible doors

Automatic barriers

Solutions for openings of up to 8 metres. Large outside areas in companies, supermarkets, hospitals, public buildings can turn into neat and comfortable parking areas. What has always been considered a problem, can become a source of income, through total access control.



UPPER

Steel structure with scratch-proof coating. ODS safety device for controlling and stopping opening/closing if an obstacle is detected. Anti-crush device. Key lock release device for manual operation. High-speed and/or heavy-duty operation.

Flexible doors



For details see next paragraph.



Overhead doors



Set your company in motion



**Professionalism, reliability,
product range and assistance all rolled into one.
The broad range of DITEC products and the professional skills
of the DITEC experts make it possible to cater for all specific
requirements and offer the advantage of a single supplier
for every type of entrance.**

▶ Gate Automations



▶ For sliding gates



For gates up to 1400-1500 kg.



For gates up to 3000 kg.

▶ For swing gates



For gates up to 5 m. Ideal for condominiums and heavy-duty use.



Special actuator with articulated arm. Necessary in case of gates mounted on very big or not perfectly vertical pillars.

▶ Automatic systems and automatic entrances

▶ For a prestige entrance



Automations and sliding doors.

▶ For offices - meeting rooms



Automations for internal concealed and swing doors. Also suitable for already-existing frames, **without modification.**

▶ For industrial doors and systems



DOR



DOD

For industrial folding, sectional, transom and sliding doors.



Sectional overhead doors

Industrial sectional overhead doors.



GOLD ALU



LISBON

▶ Industrial automatic doors

Special PVC or polyester, self-extinguishing curtain, available in a wide range of colours.

Drop-proof safety system. ACS crash-proof system.

Emergency lock release handles available on both sides in compliance with Italian Law Decree 626/94.

Easily interchangeable sections (Sector, Traffic and Stratos).

Simple, functional control panel with "self-test" function.



Roll-up doors with inner curtain. Ideal for heavy-duty use. Double opening and closing speed. Integrated and self-supporting metal structures. Galvanized steel, painted or stainless steel versions. Great aesthetic impact. Perfectly transparent versions or with coloured polyester, wide window panels. Opening up to 5x5 metres.

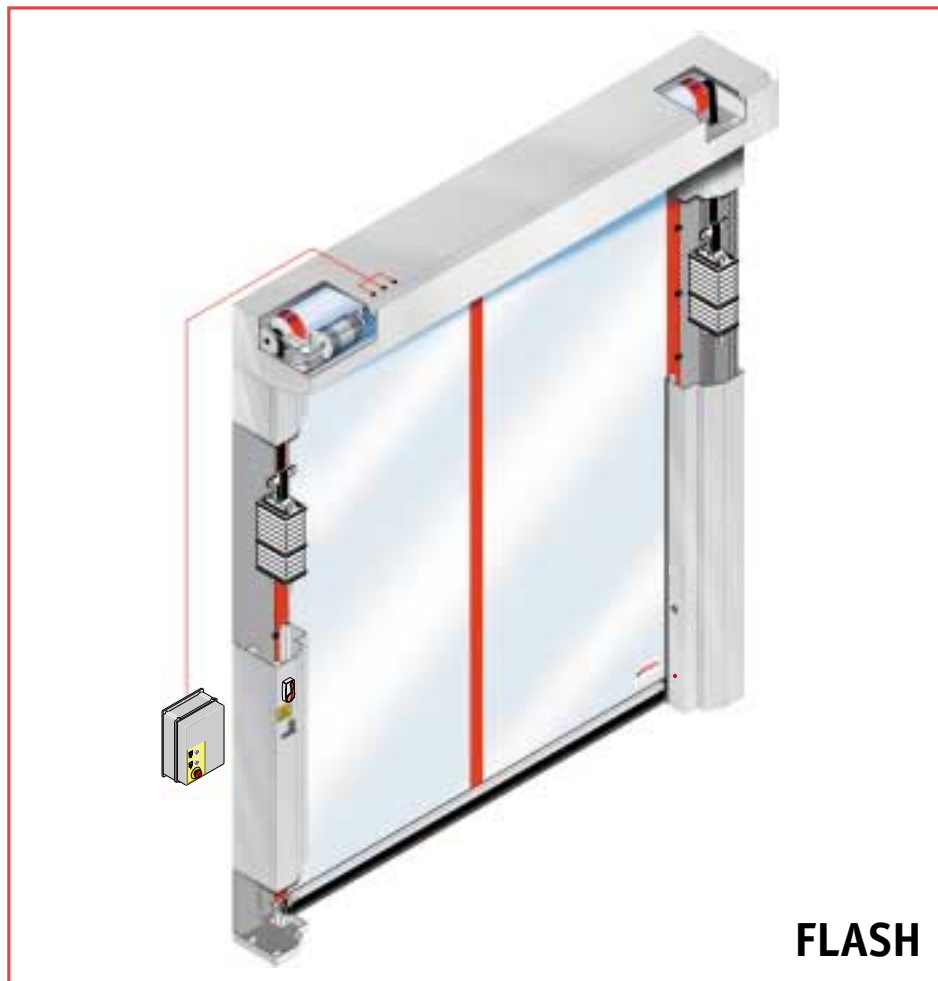



SECTOR-SMART

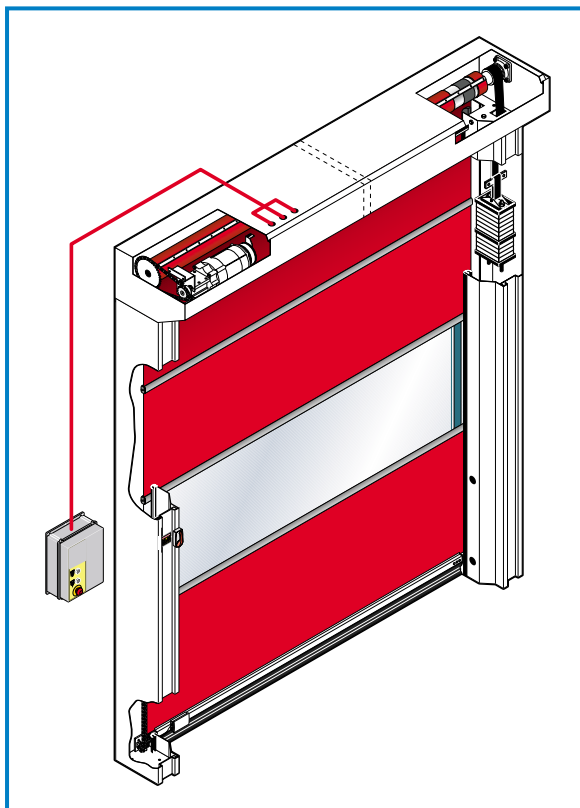

High speed, roll-up doors with interchangeable sections. Compact and integrated structures. Reduced overall dimensions make installation easy even in case of lack of space. Galvanized steel, painted, stainless steel, metal structure and anodized extrusions. Modular sections allow easy arrangement of differently coloured and transparent panels, as well as replacement in case of accidental damage. Flexible and easy installation.



KRONOS



Roll-up doors with interchangeable sections. **Self-repairable.**



TRAFFIC

High speed, fold-up door also available with interchangeable sections. Integrated and coated structure to withstand adverse weather conditions. Ideal in difficult operating conditions (strong wind or depression). Sturdy and solid. Suitable for medium and large entrances. Up to 9 x h 6 m.



FLAP



STRIP

Flexible flaps and strip closing. Practical and convenient solutions for insulation and traffic. Available in manual, semi-automatic and automatic versions. Practically divide indoor space preserving light and ensuring a high degree of heat insulation and soundproofing.



OVER

Multipurpose automation for straight sliding panels. Indispensable for heavy-duty operation. Hanging sliding doors, industrial doors, awnings and drop-curtains. Strong, sturdy and untiring.



The widest range of accessories



Each automatic system requires a series of control and safety accessories compatible with the system components and complying with regulations in force.

DITEC offers products and accessories of total quality, which satisfy any requirement.

Control accessories



MICROPROCESSOR LOGIC CONTROL PANELS

Advanced functions such as:

- Obstacle detection;
- Speed and motor power adjustment;
- SELF-TEST functional check of the system.



PROXIMITY ACCESS CONTROL

Wireless identification system with TRANSPONDER technology.

Non-contact detection.



KEY SWITCHES

High security, vandal-proof device.
Surface or flush mounting.



DIGITAL FUNCTION SELECTORS

Vandal-proof push-button station.
Secret code up to 8 figures.



TOKEN CONTROL SYSTEMS

For enabling once-only opening of automatic system.
Token with encoded mark.

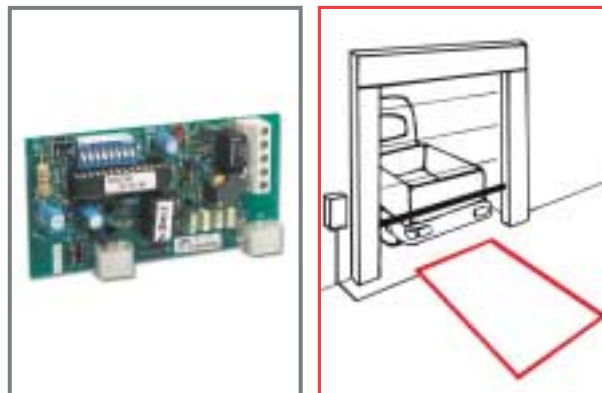

MAGNETIC LOOP DETECTORS

Starts automatic entrance opening when the vehicle passes over a sensor located on the ground.



SELF-LEARNING RADIOFREQUENCY SYSTEMS

Individual code, cannot be duplicated, stored in EEPROM.
16 million combinations.
Type-approved.



DIGITAL KEYPAD RADIOFREQUENCY SYSTEMS

Four-channel codified keypad.
For the remote-control opening of motorized entrances, by code dialling.
Surface mounting.



PUSH BUTTONS

Mechanical or pneumatic, emergency, key, push or elbow buttons.



SENSITIVE MATS

For automatically opening automatic doors by means of pedestrian transit.

DIGITAL AND ANALOGIC PROGRAM SELECTORS

For selecting and programming required automatic door function modes.

Multifunction mechanical or digital versions.



AUTOMATIC DOOR SWITCHES

COM are new electronic mechanical and electronic digital program switches designed to select and set required operation modes of one or more automatic doors.



PROGRAMMABLE CONTROL PANELS

With remote control or PC programmable flash micro-control.

Simple or advanced multi-parameter adjustment.

▶ Control accessories



VOLUMETRIC SENSORS

Allow effective monitoring of transit areas, by passage detection (people and vehicles) and automatic entrance opening control.



CABLE WINDING SYSTEM

Ensures continuous electrical connection between the mobile edge of the sliding gate and the control panel.

Safety accessories



INFRARED PHOTOCELLS

Double relay in compliance with regulations.
Surface or flush mounting.
Modulated infrared beam.



RUBBER SAFETY EDGES

Ensure highest safety conditions during automatic opening.
Provision for internal installation of self-controlled infrared beam.



SIGNAL DEVICES

Flash lights. Single or double traffic light.

To ensure regular smooth operation, buy only DITEC accessories.

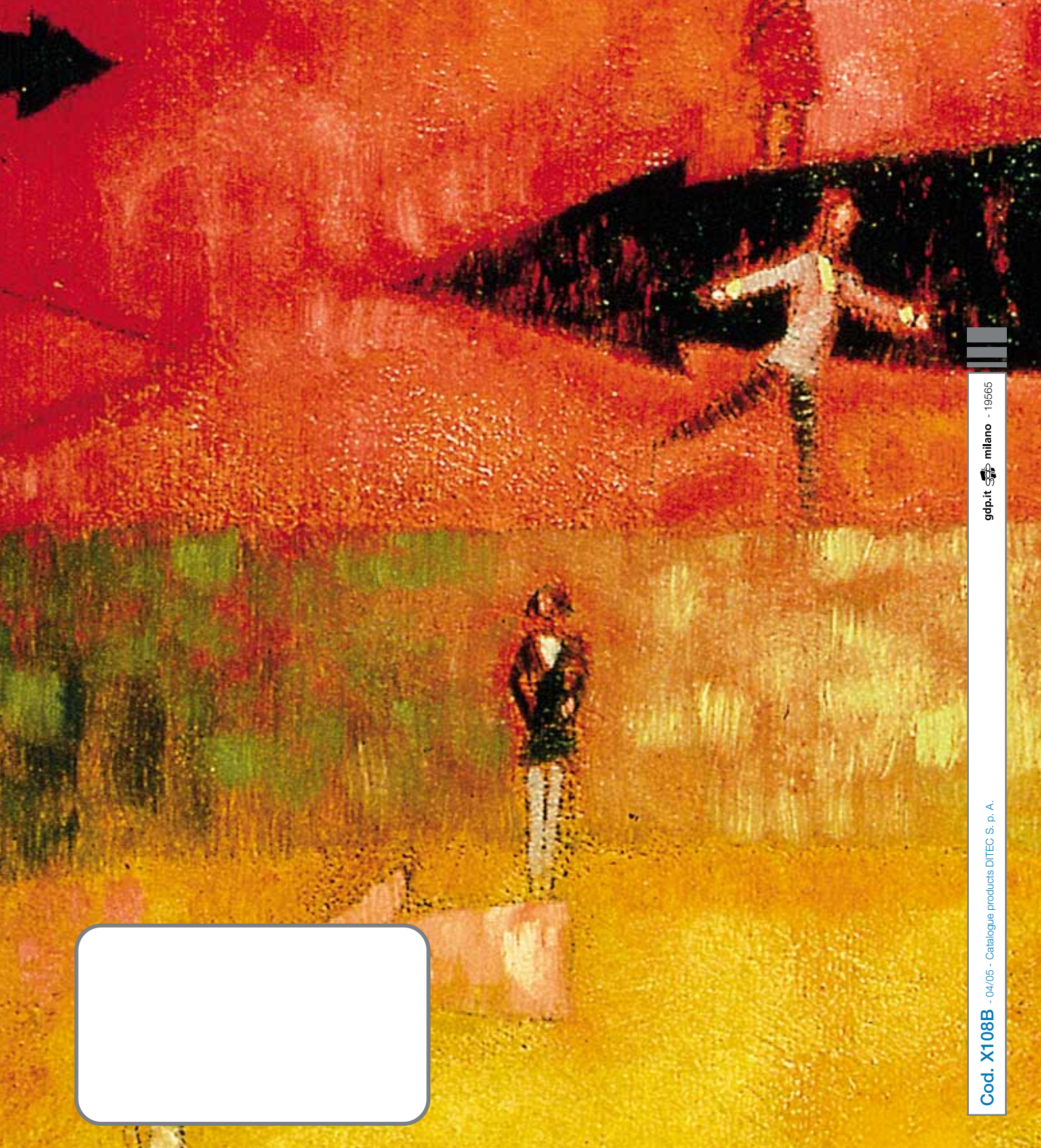

Cod. X108B - 04/05 - Catalogue products DITEC S. p. A. gdp.it milano - 19565



DITEC S.p.A.

Via Mons. Banfi, 3 - 21042 Caronno Pertusella (VA) - ITALY
Tel. +39 02 963911 - Fax +39 02 9650314
www.ditec.it - ditec@ditecva.com



ISO 9001
Cert. n° 0957

DITEC BELGIUM
DITEC DEUTSCHLAND
DITEC FRANCE
DITEC SVIZZERA
DITEC AMERICA

LOKEREN
OBERURSEL
PALAISEAU
BALERNA
ORLANDO-FLORIDA-USA

Tel. +32 9 3560051
Tel. +49 6171914150
Tel. +33 1 64532860
Tel. +41 91 6463339
Tel. +1 407 8880699

Fax +32 9 3560052
Fax +49 61719141555
Fax +33 1 64532861
Fax +41 91 6466127
Fax +1 407 8882237

www.ditecbelgium.be
www.ditec-germany.de
www.ditec.fr
www.ditecswiss.ch
www.ditecamerica.com